



# MODEL 41382VC

## RELATIVE HUMIDITY / TEMPERATURE PROBE with VOLTAGE OUTPUT

### INSTRUCTION SHEET 41382VC-90

REV F111215

#### INTRODUCTION

The Model 41382VC Relative Humidity/Temperature Probe combines high accuracy humidity and temperature sensors in a single probe. The output signal is 0-1 V (standard) or 0-5 V (user selected option) for both relative humidity and temperature. RH range is 0-100%. Temperature range is -50 to +50°C.

#### INSTALLATION

The Relative Humidity/Temperature probe should always be installed in a protective radiation shield to ensure accurate data. Use of the probe without a radiation shield may result in large errors. The probe installs easily in YOUNG naturally ventilated or motor aspirated shields. For best performance, the probe and shield should be placed in a location with good air circulation clear of large masses (buildings, pavement, solar panels...), Exhaust vents, electrical machinery and motors, water fountains and sprinklers.

#### MAINTENANCE

The Relative Humidity/Temperature probe is designed to offer years of service with minimal maintenance. As with most humidity sensors, humidity calibration may drift slightly with time, and can be checked or restored at the factory. Periodically clean the humidity sensor filter when used in areas of high dust or contamination (smokestacks, seawater, etc.) Remove from sensor and soak in clean water or use a mild soap solution. DO NOT USE SOLVENTS.

#### WARRANTY

This product is warranted to be free of defects in materials and construction for a period of 12 months from date of initial purchase. Liability is limited to repair or replacement of defective item. A copy of the warranty policy may be obtained from R. M. Young Company.

#### CE COMPLIANCE

This product has been tested and complies with European CE Requirements for the EMC Directive. Please note that shielded cable must be used.

#### EMC COMPLIANCE

This device complies with Part 15 of the FCC Rules. Operation is subject to the following two conditions: (1) this device may not cause harmful interference, and (2) this device must accept any interference received, including interference that may cause undesired operation.

This equipment has been tested and found to comply with the limits for a Class A digital device, pursuant to part 15 of the FCC Rules. These limits are designed to provide reasonable protection against harmful interference when the equipment is operated in a commercial environment. This equipment generates, uses, and can radiate radio frequency energy and, if not installed and used in accordance with the instruction manual, may cause harmful interference to radio communications. Operation of this equipment in a residential area is likely to cause harmful interference in which case the user will be required to correct the interference at his own expense.

This ISM device complies with Canadian ICES-001.

Cet appareil ISM est conforme à la norme NMB-001 du Canada.

EN55011/CISPR 11, Group 1, Class B device.

Class B equipment is suitable for use in domestic establishments and in establishments directly connected to a low voltage power supply network which supplies buildings used for domestic purposes.

#### SPECIFICATIONS

##### RELATIVE HUMIDITY:

Measuring range: 0-100% RH  
Accuracy at 23°C: ±1%  
Stability: Better than ±1%RH per year  
Response Time: 10 seconds (Without Filter)  
Sensor type: Rotronic Hygromer

##### TEMPERATURE:

Measuring Range: -50 to +50°C  
Accuracy at 23°C: ±0.3°C  
Response Time: 10 seconds (Without Filter)  
Sensor type: Platinum RTD

Output signal: 0-1 or 0-5 VDC (jumper option)  
Power Required: 8-30 VDC at 7 mA  
Recommended Cable: 5 conductor shielded, Young 18446

##### Recommended Shields:

Young Model 43502 Aspirated Radiation Shield  
Young Model 41003P Multi-Plate Radiation Shield

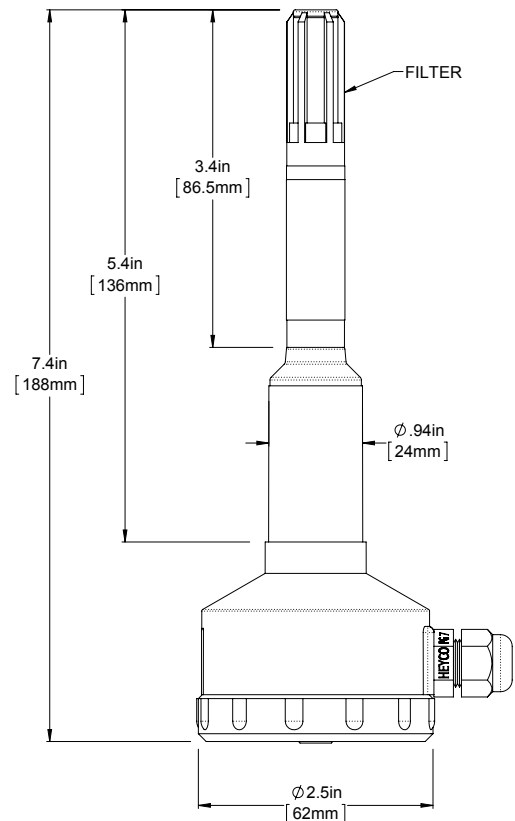



# WIRING INFORMATION

MODEL 41382VC TEMPERATURE SENSOR



## WIRING DIAGRAM

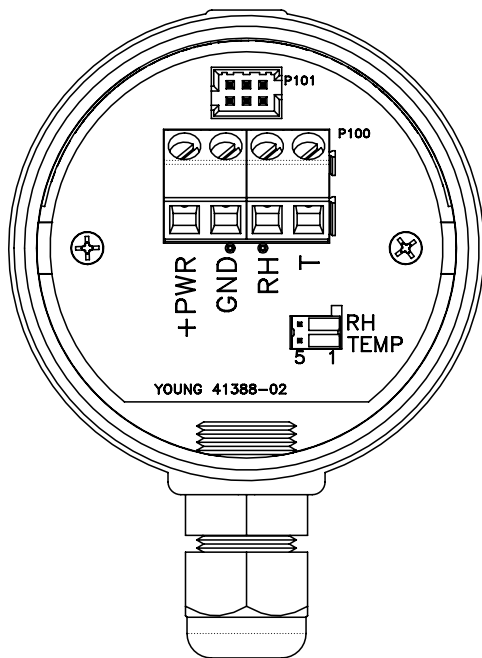
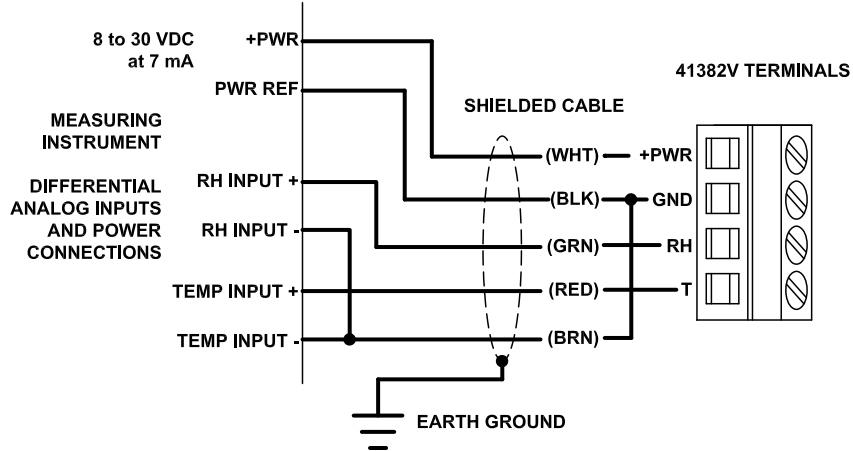

## VOLTAGE OUTPUT SELECTION JUMPERS

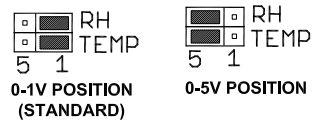

Set 0-1 V or 0-5 V output with jumpers as shown in diagram. These jumpers are located below the terminals in the junction box.